

Model AM

Manual Chain Hoist

CHESTER HOIST

Cost efficient Chester manual chain hoists are ideal for standard industrial duty, standby maintenance or in locations where electrical power is not available. Lightweight and portable, hoists are exceptionally versatile in both indoor or outdoor applications. Popular metric capabilities are one-half, one, two, three and 5 tons.

Model AM Features and Benefits

- Light in weight for easy portability
- Durable steel frame with heat treated load bearing components
- Economical in both purchase price and parts replacement
- Rugged steel gear
- 4 to 1 design factor for optimum strength at load bearing points
- Metric capacity
- Strong steel gear and handwheel covers for impact resistance and durability
- Forged steel hooks
- Simple assembly & low-maintenance features
- Load tested before shipment
- Optional load limiter available

Distributed by:



Kristian Electric Ltd.

Calgary
4215 64th Avenue SE
(403)292-9111

Edmonton
14236 121A Avenue
(780)444-6116

Saskatoon
710 46th Street E
(306)343-9111

www.kristian.ca

**Two-ton
capacity**



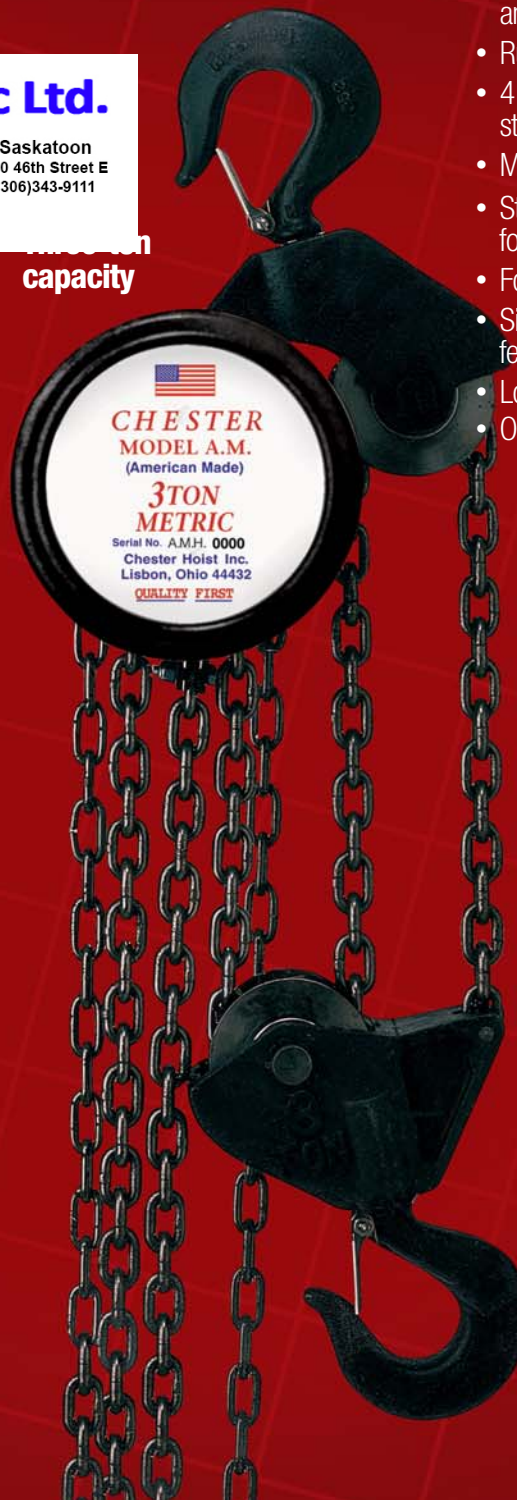

**Three-ton
capacity**



**One-ton
capacity**



CHESTER
MODEL A.M.
(American Made)
2TON
METRIC
Serial No. AM.H. 0000
Chester Hoist Inc.
Lisbon, Ohio 44432
QUALITY FIRST

CHESTER
MODEL A.M.
(American Made)
3TON
METRIC
Serial No. AM.H. 0000
Chester Hoist Inc.
Lisbon, Ohio 44432
QUALITY FIRST



CHESTER
MODEL A.M.
(American Made)
1TON
METRIC
Serial No. AM.H. 0000
Chester Hoist Inc.
Lisbon, Ohio 44432
QUALITY FIRST

Specifications

Chester Model AM

1/2 through 1 metric ton

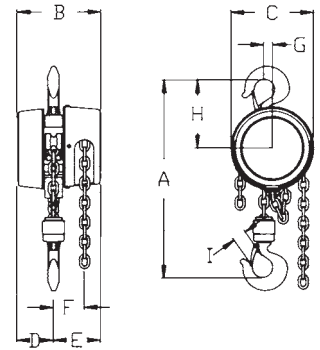
A	B	C	D	E	F	G	H	I
12-1/8"	6-1/2"	6-1/4"	2-13/16"	3-11/16"	2-1/2"	1/2"	5"	7/8"



1/2 through 1 metric ton

2 metric ton

A	B	C	D	E	F	G	H	I
16-1/2"	6-1/2"	6-1/4"	2-13/16"	3-11/16"	2-1/2"	2-1/4"	6-1/4"	1"

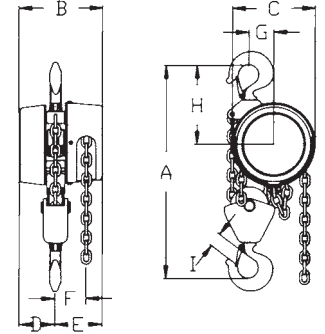

2 metric ton

3 metric ton

A	B	C	D	E	F	G	H	I
16-1/2"	6-1/2"	6-1/4"	2-13/16"	3-11/16"	2-1/2"	3-1/4"	6-13/16"	1-1/8"

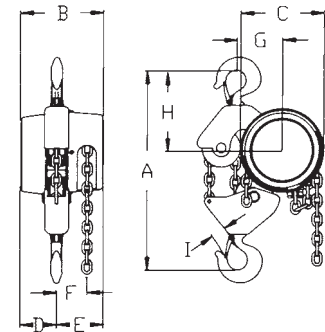

3 metric ton

5 metric ton

A	B	C	D	E	F	G	H	I
20-1/4"	6-1/2"	6-1/4"	2-13/16"	3-11/16"	2-1/2"	4-3/8"	7-7/8"	1-3/8"

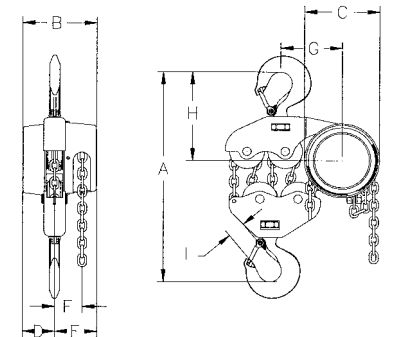

5 metric ton

CATALOG NUMBERS & SPECIFICATIONS

CATALOG #	150-1/2	150-1	150-2	150-3	150-5
CAPACITY IN METRIC TONS	1	1	2	3	5
MIN. HEADROOM	12 1/8"	12 1/8"	15 1/2"	16 1/2"	20 1/4"
ST'D. LIFT	10'	10'	10'	10'	10'
APPROX. WEIGHT.	28#	28#	38#	54#	74#
ADD FOR EACH ADDITIONAL FOOT OF LIFT OVER 10 FT.	1.2#	1.2#	1.8#	2.5#	3.6#
HAND CHAIN PULL	64#	64#	66#	68#	70#
HAND CHAIN OVERALL PER FOOT OF LIFT	44'	44'	88'	132'	220'

CHESTER
HOIST

Chester Hoist, Inc. • 7573 State Route 45 • Lisbon, OH 44432
Phone (330) 424-7248 • Fax (330) 424-3126